

Fridge door Alarm

**Beeps if you leave open the door over 20 seconds
3V battery operation, simple circuitry**

Circuit diagram:

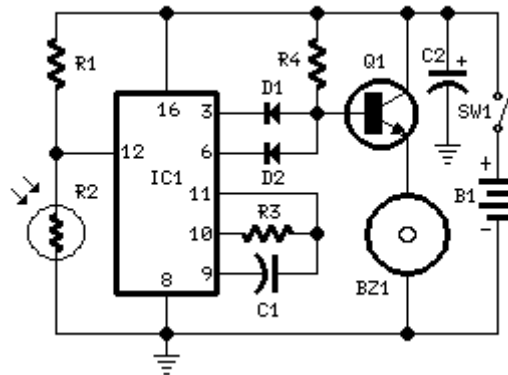

Parts:

R1 _____ 10K 1/4W Resistor
R2 _____ Photo resistor (any type)
R3,R4 _____ 100K 1/4W Resistors

C1 _____ 10nF 63V Polyester Capacitor
C2 _____ 100µF 25V Electrolytic Capacitor

D1,D2 _____ 1N4148 75V 150mA Diodes

IC1 _____ 4060 14 stage ripple counter and oscillator IC

Q1 _____ BC337 45V 800mA NPN Transistor

BZ1 _____ Piezo sounder (incorporating 3KHz oscillator)

SW1 _____ Miniature SPST slide Switch

B1 _____ 3V Battery (2 AA 1.5V Cells in series)

Circuit operation:

This circuit, enclosed in a small box, is placed in the fridge near the lamp (if any) or the opening. With the door closed the interior of the fridge is in the dark, the photo resistor R2 has a high resistance (>200K) thus clamping IC1 by holding pin 12 high. When a beam of light enters from the opening, or the fridge lamp lights, the photo resistor lowers its resistance (<2K), pin 12 goes low, IC1 starts counting and, after a preset delay (20 seconds in this case) the piezo sounder beeps for 20 sec. then stops for the same lapse of time and the cycle repeats until the fridge door closes. D2 connected to pin 6 of IC1 makes the piezo sounder beeping 3 times per second.

Notes:

- | Connecting D1 to pin 2 of IC1 halves the delay time.
 - | Delay time can be varied changing C1 and/or R3 values.
 - | Any photo resistor type should work well.
 - | Current drawing is insignificant, so SW1 can be eliminated.
 - | Place the circuit near the lamp and take it away when defrosting, to avoid circuit damage due to excessive moisture.
 - | Don't place it in the freezer.
-